

DE LA RUE  
CASH SYSTEMS



DeLaRue

# 1820

## Automatic Coin Wrapper

Fast, compact coin wrapping for medium volume applications



# 1820

## Automatic Coin Wrapper

The **1820** is a fast, cost-effective, stand alone coin wrapper, suitable for medium volume coin processing applications.

### Fast, Efficient Throughput

The **1820** increases productivity by accurately wrapping up to 20 rolls of coins per minute. Fitted with magnetic count sensors, the highest degree of accuracy is guaranteed at all times.

### Easy to Use

The **1820's** hopper height is conveniently positioned for the loading of coin, reducing operator fatigue. A top door on the **1820** provides convenient access to the coin track, allowing jams to be easily cleared.

The **1820's** unique coin stacking mechanism eliminates the need for a coin tube per denomination, allowing easy denomination changeover.

### Compact

Utilizing minimal floor space, the **1820** will fit into almost any coin environment. Fitted with large, heavy duty casters, the **1820** can be easily and safely transported.

### Multiple Functionality

The **1820** is pre-set with various roll stops by denomination, meaning the standard roll count for a particular denomination is automatically set, eliminating operator error. The **1820's** batching capability allows the operator to wrap a pre-set number of coin rolls.

A built-in bagging spout also allows coin to be bagged, with the adaptation to this function being quick and easy. Bag stops can be programmed to 9,999 coins for complete processing flexibility.

De La Rue Cash Systems coin and currency processing products are the direct result of 100 years experience in the design, manufacturing and distribution of world class cash handling solutions. Worldwide service and support is provided through De La Rue Cash Systems' network of branch offices and authorized distributors.

## Technical Specifications

### Coin size range

Diameter: 0.60" to 1.30" (15.0mm to 33.0mm)  
Thickness: 0.04" to 0.14" (1.0mm to 3.5mm)

### Input hopper capacity

Up to 5,000 coins

### Paper roll capacity

Up to 1,000 foot roll

### Count speed

Up to 1,500 coins per minute

### Wrap speed

Up to 20 rolls per minute

### Coin denominations

Up to 6 different wrapping positions

### Programmable batch stops

Up to 9,999

### Stack height

All standard U.S. coin stack heights, plus nickel and quarter half-wraps

### Power supply

115 VAC ( $\pm 10\%$ ), 60Hz

### Dimensions

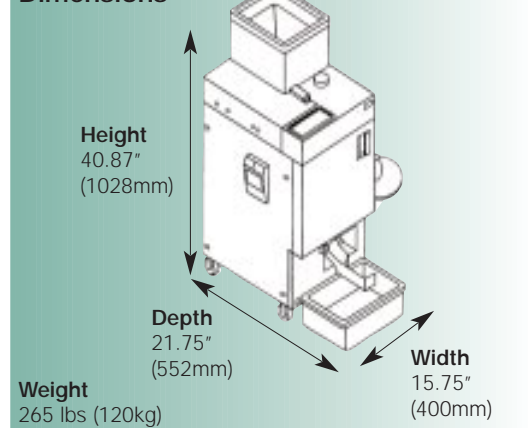

BS EN ISO 9001  
FM 689



This leaflet is for general guidance only. De La Rue Cash Systems is pleased to give detailed specifications of its products in this leaflet. As the Company's products and services are continually being developed, it is important for the customer to check that the information contained herein includes the latest particulars. This document is not part of a contract or license save insofar as may be expressly agreed.

Copyright © 2002 De La Rue Cash Systems Inc.  
De La Rue and the Founders Head Device is a registered trademark of De La Rue plc

### DE LA RUE CASH SYSTEMS

2441 Warrenville Rd.  
Lisle, IL 60532

Telephone: (800) 527-2638

Fax: (630) 577-1270

Web: [www.delarue.com](http://www.delarue.com)

